

Spiral A



Removable bowl Spiral mixer

Performances

- Flour capacity : from 5 to 158 kg
- Dough capacity : from 8 to 253 kg
- Bowl volumes : from 250 to 360 litres depending on models.

The advantages

- 2 mixing speeds
- Inversion of the rotation direction of the bowl in 1st speed
- Adaptability to Bongard hydraulic hoists (Tilti and BDC) (Attention : for any installations with an existing EBCV bowl lifting & tilting hoist, an adaptor kit is needed (ref. 2B001042).
- Allows to mix small quantities of dough
- A choice of 2 electronic

Use

Mixing is the 1st bread-making operation that blends the raw materials to make the dough. Bongard spiral kneaders Spiral A with removable bowl are used in the manual mixing process including following phases : mixing the ingredients in a dough mass, cutting the dough for homogenization, consistency, softness and elasticity, stretching and oxygenation to improve dough whiteness, increase its extensibility and fineness. For professional use, they are ideal for all types of dough.

Operating principle

The different ingredients are placed in the mixing bowl. The 1st speed is used for initial blending of ingredients. The 2nd speed is used to cut, stretch and air the dough. The different controls offer the possibility of manual or automated management. The bowl can be removed from the structure to add ingredients and for use with a Bongard bowl lifting & tilting hoist.

Construction

- Reinforced rigidified steel structure with external structure coated with epoxy (food grade)
- Front surface of head and body coated with stainless steel protective layer
- Structure mounted on 6 feet for easy cleaning
- Lower edge of stainless steel bowl specially shaped with «almond-shaped beading» to provide better coupling between the driving system and the bowl
- Bowl strengthened by a welded flat strip
- Stainless steel arm, bowl and dividing blade
- Easy fitting and removal of the bowl using the hydraulic head lifting mechanism
- Bowl pre-connection device makes it easy to fit the machine on an uneven surface
- Friction wheel transmission for the bowl drive
- Belt and pulley transmission
- Power supply : 400V 3 PH+N 50/60 Hz

Models :

Safety see-through lid for a better reduction of flour dust

- Electronic control « basic mode » : same function as Spiral control type E
- Electronic control « advanced mode » : large LCD display, possibility to manage, memorize and save by name 99 recipes, signal for malfunction, variable rotation speeds (+ or -10%)

Options available : Infrared temperature probe, Ingredient containers

- Electronic control « basic mode » : see description above
- Electronic control « advanced mode » : see description above

Spiral A Removable bowl spiral mixer

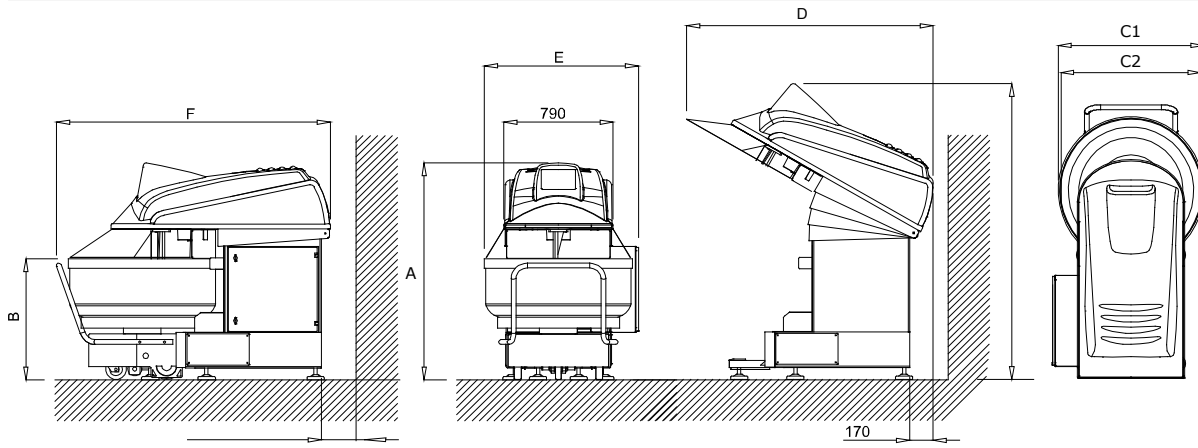

Options (on demand)
infra red temperature probe (LCD models)
Ingredient container (maximum 2) (LCD models)
Stainless steel frame

Accessories
Extra bowl on trolley Spiral A 250
Extra bowl on trolley Spiral A 300
Extra bowl on trolley Spiral A 360

Capacity : mixer and/or additional bowl for models (indicative values)				
Model	Flour (kg)	Dough (kg)	Pouring (litre)	Total litre
Spiral A 250**	80 - 100	120 - 160	48 - 60	250
Spiral A 300	5 - 125	8 - 200	3 - 75	300
Spiral A 360	7 - 158	11 - 253	4 - 95	360

Model	Total power (kW)	Net weight (kg)	Arm speed 50 Hz (rpm)	Bowl speed 50 Hz (rpm)	Arm speed 208 / 220 V 60 Hz (rpm)	Bowl speed 208 / 220 V 60 Hz (rpm)
Spiral A 250**	10	1210	107 - 214	12,9	107 - 214	12,9
Spiral A 300	10	1210	107 - 214	12,9	107 - 214	12,9
Spiral A 360	13,6	1265	107 - 214	12,9	107 - 214	12,9
Bowl 250**	-	280	-	-	-	-
Bowl 300	-	295	-	-	-	-
Bowl 360	-	325	-	-	-	-

Model	Dimensions (mm)							
	A	B	C1	C2	D	E	F	G
Spiral A 250**	1064	865	930	900	1790	1045	1860	2190
Spiral A 300	1604	927	930	900	928	1045	1860	2190
Spiral A 360	1604	895	1080	1045	1075	1120	1980	2190
Bowl 250**	0	865	930	900				
Bowl 300	0	927	930	900				
Bowl 360	0	895	1080	1045				

Packing					
Mainland (Cardboard box on pallet)	Model		Spiral 250	Spiral 300	Spiral 360
	width	(mm)	1250	1250	1400
	length	(mm)	2050	2050	2200
	Height	(mm)	1800	1800	1800
	Weight	(kg)	1300	1300	1400
By Sea (Wooden Crate)	Model		Spiral 250	Spiral 300	Spiral 360
	width	(mm)	1350	1350	1500
	length	(mm)	2150	2150	2300
	Height	(mm)	1900	1900	1900
	Weight	(kg)	1400	1400	1500

Control panel Spiral A



Electronic « Basic mode »
control panel type E



Electronic « Advanced mode »
control panel type LCD

Electronic controls

Electronic control panel « Basic mode » type E

Use

- 9 mixing programs are available
- Electronic controls with digital display and high resistance membrane keyboard
- Can be used in manual or automatic mode
- Electronic controls can memorise times used in 1st and 2nd gears
- Times can be changed without stopping the mixer
- Reverse bowl rotation available on all models except
- Buzzer sounds on completion of the mixing cycle

Characteristic properties for control panel type E

Manual mode : used to test the mixing time of a recipe before programming it. It is possible to program up to 9 recipes.

Automatic mode : used to start a program. Times are decremented then the mixer switches automatically from the 1st to the 2nd gear.

Electronic control panel « Advanced mode » type LCD

Use

- programs available
- All functions and programs are displayed on an LCD screen.
- Electronic control with digital display and high resistance membrane
- Manual function
- Automatic function
- Two «favourite» program keys give direct access to the most frequently-used recipes
- Buzzer sounds on completion of the mixing cycle
- A 1st-gear reverse bowl rotation facility enables the user to mix small quantities

■ Important notes :

If the mixer is fitted with the "see through" lid, it is possible to start mixing in 2nd speed. Fitted with a grid, to comply with the CE norm, the 1st speed will take at least 2 minutes

The advantages

- Manual or automatic cycle
- Setting of 1st and 2nd speed
- Optimized control of the recipes
- Thanks to its "see through" lid, it is possible to start the mixing program in 2nd speeds

Electronic control panel « Basic mode » type E

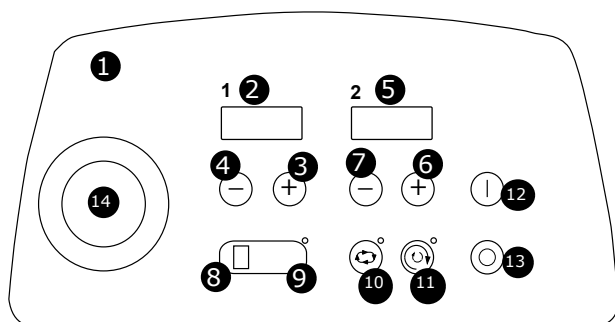

- | | |
|---|--|
| 1 High resistance membrane keyboard | 8 Display of the selected program |
| 2 Display of the first speed | 9 Selection of the program with key |
| 3 Increase the time of the first speed | 10 Automatic or manual function with key |
| 4 Decrease the time of the first speed | 11 Function of reverse bowl rotation. Except the models Spiral 50 and 70 |
| 5 Display of the second speed | 12 Start the cycle |
| 6 Increase the time of the second speed | 13 Stop the cycle |
| 7 Decrease the time of the second speed | 14 Emergency/Stop button |

Electronic control panel « Advanced mode » type LCD

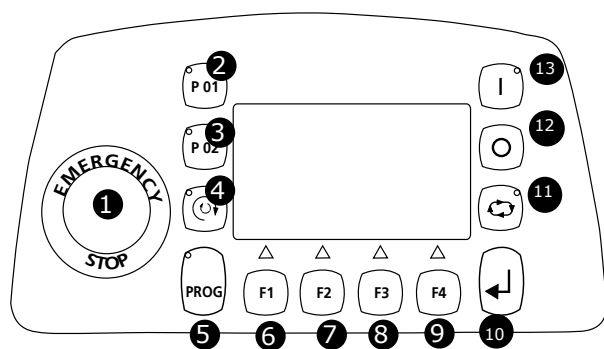

- | | |
|--|-------------------------------------|
| 1 Emergency stop button | 8 Same function as n°6 |
| 2 First program n° 1 | 9 Same function as n°6 |
| 3 First program n° 2 | 10 Validation of programming choice |
| 4 Inversion of the bowl rotation | 11 Manual cycle or Automatic cycle |
| 5 Last recorded program recall | 12 Stop the cycle |
| 6 Multiple functions can be viewed on screen | 13 Start the cycle |
| 7 Same function as n°6 | |