



BONGARD

Always by your side

| RESTING CABINET

RP

Higher output,
smaller footprint



MADE IN FRANCE



RP is a resting cabinet with carriers and a manual loading/unloading system. It is used after dividing the dough, to promote gluten relaxation during the first rise and make the dough easier to mould. When closed, RP maintains a constant environment which helps the aromas to develop and prevents crusting.

Thanks to its **small footprint**, **RP** can easily be integrated into any artisan bakery. Its **high storage capacity** and **user-friendly design** make bakers' **work easier**.

RP comes in several sizes for different needs. The largest model can hold up to 160 large (1 kg) dough pieces.



Efficient
Compact

Versatile
Practical
User-friendly



A compact resting cabinet that's easy to use

The comfortable working height and easily accessible controls make **loading and unloading very straightforward**.

The cabinets are compact (**footprint of less than 1.5 m²** for the smallest models) yet spacious (**224 to 360 dough pieces (350 g)**).



A resting cabinet that's easy to clean

The carriers, which come in a **choice of felt or nylon mesh**, are attached using Velcro, so they can **easily be removed and cleaned** (machine-wash on a cold cycle).

For added piece of mind, an optional hygiene kit is also available (**UV lamps and blower**).



A resting cabinet that simplifies dividing, rising and moulding

The Bongard **MAJOR** moulder can be directly connected to **RP** and mounted on top of it. The control panel also has another connection point, which can be used to connect a **MERCURE** divider.

Connecting and combining machines optimises floor space and **improves working conditions** for bakers as everything is closer together.



Tips from our bakers and pastry chefs



For high-hydration doughs (>65%) we recommend the felt carriers.

RP optimises floor space, increases output, and improves working conditions

A resting cabinet with a small footprint and a user-friendly design

Quieter working environment:

Noise level < 70 dBA



User-friendly:

Felt-covered rounding tray for finishing moulding by hand when required



Durable and robust:

Steel frame with an epoxy paint coating



Easy to use:

Pushbuttons on both sides of the machine to move carriers step-by-step



Easy to move:

4 multi-directional castors (with brakes at the front)



Customisable:

Choice of felt or nylon mesh carriers



Work in complete safety with RP



Our commitment to safety goes beyond self-certification since we have our equipment audited by an independent external body.

RP can be combined with our **MAJOR** moulder for ultimate convenience

Optimise floor space and boost productivity!

Dough pieces can be taken out of **RP** and placed directly in the moulder.



Intuitive controls



Our experts at your service

Sales expertise

Our sales and installation teams can help you decide on the best equipment and layout for your production process and offer support at every stage of your project.

For the French market, we also offer financial leasing solutions through a dedicated division, Bongard Finance. This agile financing method preserves cash flow and is a first in the bakery and pastry goods market.

Business expertise

At our head office in Holtzheim, France, we have a 320 m² showroom and laboratory where you can come and try out our equipment in line with your own production processes. Contact us to arrange a visit.

Wherever you are in the world, we can arrange for our master bakers to visit your premises and train you on our machines.

Technical expertise

Our equipment is covered by the manufacturer's warranty from the moment of delivery. To optimise the service life of your equipment and avoid costly downtime, you can also take out a maintenance contract and/or an extended guarantee.

The technicians at our dealerships and distributors receive regular training so they are fully qualified to keep your equipment in good working order.

Our dealers and distributors have access to an online platform where they can consult technical documentation and order spares from a catalogue of around 5000 original parts, which ship within 24 to 48 hours.



RP Technical Data

	RP1	RP2	RP3	RP4	RP5
Carrier material*					
Food-grade felt	•	•	•	•	•
Nylon mesh	0	0	0	0	0
Rounding table					
Felt surface	•	•	•	•	•
Plastic surface	0	0	0	0	0
Options					
Foot pedal	€	€	€	€	€
Hygiene kit (UV lamps and blower)	€	€	€	€	€
Supplied					
Unassembled	•	•	•	•	•
Assembled	€	€	€	€	€
Supply voltage					
400 V 3 PH + N + Gr 50 Hz	•	•	•	•	•

• : Standard 0 : Free option € : Option with extra charge - : Unavailable

* Nylon mesh pocket-shaped carriers: contact us.

Performance						
Number of carriers		32	32	40	40	32
Maximum weight per dough piece	(g)	630	630	630	630	1000
Power	(kW)	0.25	0.25	0.25	0.25	0.25
Capacity						
Number of 350 g dough pieces	Per carrier	7	9	7	9	9
	Total	224	288	280	360	288
Number of 550 g dough pieces	Per carrier	6	7	6	7	7
	Total	192	224	240	280	224
Number of 1000 g dough pieces	Per carrier	0	0	0	0	5
	Total	0	0	0	0	160
Dimensions and weight						
Width (L)	(mm)	1304	1644	1304	1644	1644
Depth (P)	(mm)	1050	1050	1270	1270	1270
Depth (with shelf open) (PT)	(mm)	1250	1250	1470	1470	1470
Height (H)	(mm)	998	998	998	998	998
Height with motor (HM)	(mm)	1275	1275	1275	1275	1275
Loading height (HC)	(mm)	890	890	890	890	890
Carrier dimensions	(mm)	1060 x 130	1400 x 130	1060 x 130	1400 x 130	1400 x 155
Net weight	(kg)	253	284	283	320	320

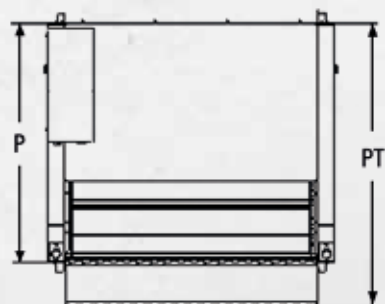
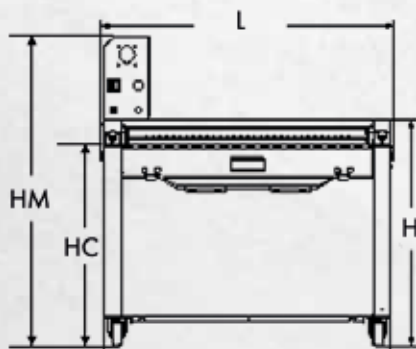



BONGARD

Always by your side

BONGARD is a French company that has been manufacturing bakery equipment since 1922. We have established a network of exclusive dealers who provide commercial and technical services throughout France and in the French overseas departments and territories. All dealers receive regular training on all our product ranges. We also have distributors in more than 140 countries around the world.

To find a distributor near you, please go to:
<https://www.bongard.fr/en/distributor/>

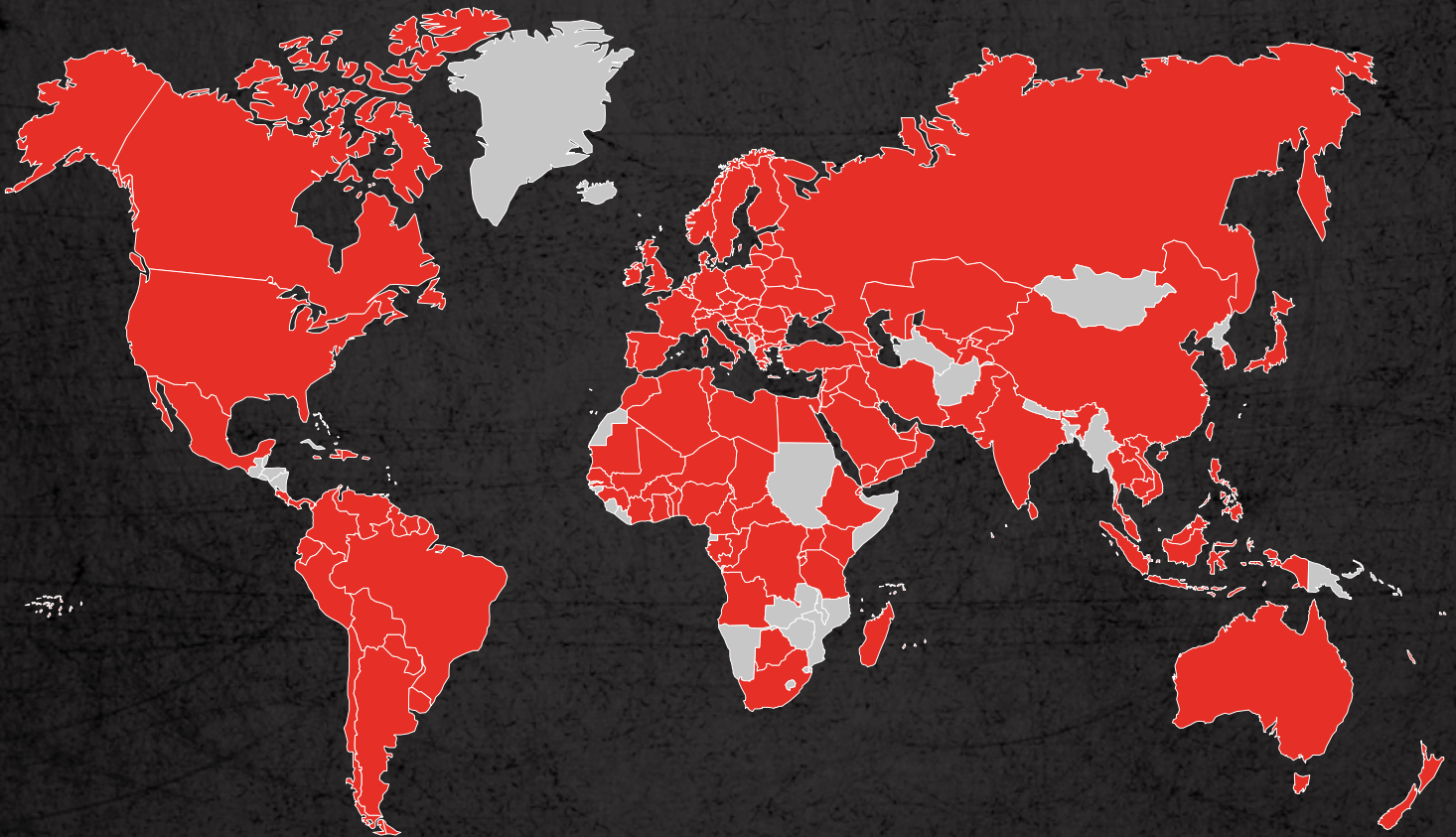

Follow us:



Bongard.bakery



Bongard_bakery



BongardBakery



Bongard

BONGARD

32 route de Wolfisheim - 67810 HOLTZHEIM (France) - Tel. +33 3 88 78 00 23 - www.bongard.fr - bongard@bongard.fr

an Ali Group Company



The Spirit of Excellence