

# ORION EVO

Controlled  
quality baking



The **ORION EVO** range of electric deck ovens, Bongard's best-seller, comes with 3 to 5 decks, in 1, 2 or 3 tracks of 600 or 800 mm for deck depths between 120 to 240 cm.

Highly responsive, the **ORION EVO** maintains production output rates with precise energy consumption management.

With state of the art technology, it offers an unparalleled level of excellence in the **control** and **precision** of baking and pastry products.

The true brain of the oven is its INTUITIV'2 control unit, which manages all the decks and makes baker and pastry chef's lives easier, from programming recipes, to delayed start baking and independent baking management.

Multi-purpose, it is ideal for cooking all types of dough, whether fresh, cold (namely if you work with the PANEOTRAD® method) or frozen raw dough.



Performance  
Reactive  
Lasting

Multi-purpose  
Intelligence



## Excellent baking quality

**ORION EVO** has an unparalleled level of excellence in the **control** and **precision** in baking products.

The absence of temperature interference between decks, made possible by reinforced sealing and thermal insulation, ensures **perfect baking consistency**. Different types of breads and pastry products can be cooked simultaneously.

High quality **steam** is produced in **just the right amount** thanks to one steam generator per deck and precise settings in millilitres.

Available as an option, the **motorised steam vent** is **highly recommended** for pastry products such as meringues, macarons, choux or puff pastry which it helps to dry. It is also useful at the end of baking bread.

The **ORION EVO** can be equipped with a **ROC deck** (Optimised Baking Radiation). Its 4 refractory hearth plates on all sides of the cooking chamber increase the thermal inertia just like in an old-fashioned oven. The heat is gentle and particularly adapted to provide **large pieces of dough** with a **thick crust**.



## Tips from our bakers and pastry chefs



For optimum baking in an electric deck oven, the top temperature must be slightly higher than the bottom with a difference of between **5** and **15°C**.



## An oven that keeps up with the pace

Ovens from the **ORION EVO** range can bake up to 15 kg of cold dough an hour per m<sup>2</sup> of deck. For example: including loading and unloading time, an oven with one 800mm track and four decks 160cm deep can bake 215 baguettes per hour.

A “boosted baking capacity” option is also available. Ideal for quick baking and/or with an increased load of dough, this option makes it possible to bake up to **18 kg of dough an hour per m<sup>2</sup> of deck.**

**ORION EVO** is **highly responsive**. Its power coupled with excellent chamber insulation allows a rapid increase in temperature which it maintains over time. The oven is **quickly ready** to restock the shelf throughout the day.



## Tips from our bakers and pastry chefs



For continuous baking times of less than 15 minutes, the boosted capacity option is recommended.

## Precise energy consumption management

With **ORION EVO**, particular attention has been paid to controlling energy consumption in order **to optimise its operating costs**.

The reinforced leaktightness of the windows and the addition of a high-performance reflective treatment on the inner surface of the glass **greatly reduces heat loss in the baking opening**.

The INTUITIV'2 control panel ensures centralised energy management. The **power is automatically assigned to where it is needed** without user involvement.

The **“Delayed start”** function is used to define the precise minute at which a deck must be at temperature to start the programmed recipe. Precise energy management for **greater usability**.

The **“Energy Saving”** function automatically manages putting the decks on stand-by, after a defined time, when not being used. A **waste in energy consumption** is thus **avoided**.



## Tips from our bakers and pastry chefs



Manual steam injection before loading is not advised. This steam could escape when the door opens, causing energy waste and unwanted costs. The **Recipes mode is used to very simply set** steam injection at the start of each bake and/or other moments if needed.

# ORION EVO has been designed to make your life easier

## Enhanced steam system:

The steam is distributed evenly throughout the baking chamber, **without the risk of water splashing**, thanks to a diffuser on the outside of the reinforced casing. A decompression valve, ensuring **optimum durability**, completes the system.



## Motorised Oura Vent (optional):

The motorised vent, which can be programmed using the INTUITIV'2 control panel, is used to **control steam evacuation** during baking.

## Easy window maintenance:

The windows can be tilted to make **cleaning quick and easy**. They can also be disassembled without tools.



## Optimised cleaning:

The "smooth deck" design of the oven mouth (patented by Bongard) allows **quick and efficient cleaning** of the baking chamber.

To avoid all risk of deterioration during this operation, the sensors in the roof are equipped with a protection system.

## INTEGRATED lifter LIFT'EVO (optional):

For greater ease of use, ORION EVO can be equipped with an integrated lifter LIFT'EVO with its dedicated loader/unloader.

Adjustable to the user's working height, it **promotes better posture**. Electric assistance is also available on some models.

**With ORION EVO, work in complete safety**



Our commitment to safety goes beyond self-certification since we have our equipment audited by an external independent body. Our equipment complies with all current standards.

## Intuitive and smooth control panel

The **ORION EVO** range is provided with the INTUITIV'2 touch control panel as standard, which intelligently manages the decks of the oven via its 10 inch screen.

Its clear and simple interface makes it very easy to use and offers a wide range of settings.

It comes with **Bongard Connect**, a new exclusive digital service that allows bakers to manage their equipment remotely.

Find out more about Bongard Connect



Depending on your needs, the oven can also be equipped with an electromechanical Ergocom control panel on each deck.

**Baking management**  
in manual mode or  
in Recipe mode

**Scheduling of delayed**  
baking start-ups per  
deck and per day

**Remote maintenance access** for  
technicians

**Consultation of the oven production**  
and energy statistics

**Temporary deactivation of the**  
touchscreen for cleaning the control  
unit's protective glass

**Recipe creation**  
(temperature, duration,  
steam injection  
and our vents operation)

**Manage custom permissions**  
depending on the user profile  
(authorisation or not to modify the  
saved recipes, access settings, etc.)

**Customise the oven**  
and access the "Energy Saving"  
function

The central image shows the BONGARD INTUITIV'2 control panel with the following icons and labels: 09:29 - Tue 25/06/2024, BONGARD INTUITIV'2, Baking, Recipes, Delayed starts, User, Bongard Connect, Settings, Statistics, Information, and a lightbulb icon.

# Our experts at your service

## Our sales expertise

Our sales and installation teams are here to help you carry out your project: they offer equipment and bakery layout recommendations adapted to your production process.

For the French market, we also offer a service dedicated to financial leasing: Bongard Finance. An agile financing method that preserves cash flow, a first in the bakery and pastry goods market.

## Our business expertise

Our 320 m<sup>2</sup> showroom and laboratory at our head office in Holtzheim is available on request for you to test our equipment according to your own manufacturing process.

Our expert master bakers come to your bakeries, at your request, all over the world, to train you on our machines.

## Our technical expertise

Our equipment is covered by the manufacturer's warranty from the moment of delivery. You can choose a maintenance contract associated with an extended warranty in order to sustainably optimise the operation of your equipment and avoid costly downtime.

BONGARD provides training to technicians from dealerships and distributors in order to ensure the proper functioning and durability of your equipment. Our dealers and distributors have access to an online platform containing technical information and allowing them to order some 5,000 references of original spare parts, shipped within 24 to 48 hours.



# ORION EVO Technical Data

	ORION EVO 1 or 2 tracks	ORION EVO 3 tracks
<b>Access to resistors / steam generator / handle side / control unit side</b>		
All on the left	•	•
All on the right	0	0
<b>Control units</b>		
INTUITIV'2 control unit (1 central control unit)	•	•
ERGOCOM control unit (1 control per deck for oven with 3- 4 decks)	0	-
ERGOCOM control unit (1 control per deck for oven with 5 decks)	€	-
<b>Baking deck equipment</b>		
4 <sup>th</sup> ROC deck (for 4- or 5-deck ovens), including our vent	€	-
Decompression on each deck (except the ROC deck)	•	•
Motorised steam vent on the upper deck	€	€
Motorised steam vent on each deck	€	€
Resistor protection system in the top	•	•
Opening compatible with a bottom hook loader-unloader	€	€
<b>Baking capacity/energy management (only with INTUITIV'2)</b>		
Centralised energy management	•	•
Boosted baking capacity	€	€
Energy management optimiser	€	€
GTC system compatibility	•	•
<b>Scalability</b>		
3-deck oven scalable up to 4 decks (to be specified when ordering)	€	-
4 <sup>th</sup> deck kit (to assemble later)	€	-
<b>Steam</b>		
Pulsating steam injection	•	•
1 water meter per steam generator (Intuitiv'2 only)	•	•
Anti-scale filter fitted with 1 cartridge	•	•
Without water filter to prevent scale deposits	-€	-€
Pressure reducer kit	•	•
<b>Accessories</b>		
Bench (excl. 5-deck oven)	•	•
Hood with exhaust fan and lighting	•	•
Oven hook system	€	€
Integrated lifter LIFT'EVO (with loader repositioning system)	€	€
Motorised integrated lifter LIFTEO (only for 1 x 800mm)	€	-
Stainless steel loader	€	€
<b>Panels</b>		
Stainless steel front with metal side panels in pre-lacquered grey steel	•	•
Full stainless steel oven housing	€	€
<b>Assembly</b>		
Oven to be assembled on site	•	•
Base 12 mm	€	€
Oven shipped mounted on a base	Consult us	Consult us
<b>Power supply voltage</b>		
3N ~ 400 V	•	•



## ORION EVO - Black Edition



To celebrate our centenary, a special edition of the **ORION EVO** oven is available as a 1-track 800 mm, 4 deck, with optional integrated lifter.

Its black design, embellished with the "Since 1922" golden label, adds a touch of elegance to any bakery.

The series is numbered and limited to 100 ovens.

# ORION EVO Technical Data

Technical features												
Models	Overall depth	Floor depth	Oven width	Overall height	Frontal oven height	Oven + loader depth	Oven depth with integrated lifter	Height with integrated lifter (excluding loader + stop)	Baking area	Floor area	Total weight of the empty assembled oven, no base, no option	Connection power
	A	B	C	D	E	F	G	H	(m <sup>2</sup> )		(kg)	
(mm)												
<b>ORION EVO - 1 x 800 mm - 3 decks</b>												
801/3.120	2252	2204				4226			2.8	3.2	1447	Standard electricity tariff
801/3.160	2666	2618				5010			3.8	3.8	1638	Standard electricity tariff
801/3.180	2878	2830	1441	2682	2200	5593	1645	2301	4.3	4.1	1868	Standard electricity tariff
801/3.200	3072	3024				5802			4.8	4.4	1949	Standard electricity tariff
801/3.220	3282	3234				6386			5.3	4.7	2035	Standard electricity tariff
801/3.240	3477	3429				6580			5.8	5.0	2140	Standard electricity tariff*
<b>ORION EVO - 1 x 800 mm - 4 decks</b>												
801/4.120	2252	2204				4226			3.8	3.2	1857	Standard electricity tariff
801/4.160	2666	2618				5010			5.1	3.8	2109	Standard electricity tariff
801/4.180	2878	2830	1441	2682	2200	5593	1645	2301	5.8	4.1	2422	Standard electricity tariff*
801/4.200	3072	3024				5802			6.4	4.4	2520	Standard electricity tariff*
801/4.220	3282	3234				6386			7.1	4.7	2646	Consult us
801/4.240	3477	3429				6580			7.7	5.0	2770	Consult us
<b>ORION EVO - 1 x 800 mm - 5 decks</b>												
801/5.120	2242	1812				4226			4.8	2.6	2338	Standard electricity tariff*
801/5.160	2656	2226				5010			6.4	3.2	2630	Standard electricity tariff*
801/5.180	2868	2438	1441	2682	2200	5593	1645	2301	7.3	3.5	3089	Consult us
801/5.200	3062	2632				5802			8.1	3.8	3204	Consult us
801/5.220	3272	2842				6386			8.9	4.1	3350	Consult us
801/5.240	3467	3037				6580			9.7	4.4	3475	Consult us
<b>ORION EVO - 2 x 600 mm - 3 decks</b>												
602/3.120	2252	2204				4242			4.3	4.2	1852	Standard electricity tariff
602/3.160	2666	2618				5026			5.8	4.9	2103	Standard electricity tariff*
602/3.180	2878	2830	1889	2682	2200	5608	2093	2301	6.5	5.3	2469	Standard electricity tariff*
602/3.200	3072	3024				5802			7.2	5.7	2615	Standard electricity tariff*
602/3.220	3282	3234				6401			7.9	6.1	2713	Consult us
602/3.240	3477	3429				6596			8.6	6.5	2824	Consult us
<b>ORION EVO - 2 x 600 mm - 4 decks</b>												
602/4.120	2252	2204				4268			5.8	4.2	2414	Standard electricity tariff*
602/4.160	2666	2618				5052			7.7	4.9	2762	Consult us
602/4.180	2878	2830	1889	2682	2200	5634	2093	2301	8.6	5.3	3300	Consult us
602/4.200	3072	3024				5828			9.6	5.7	3460	Consult us
602/4.220	3282	3234				6427			10.6	6.1	3602	Consult us
602/4.240	3477	3429				6622			11.5	6.5	3756	Consult us
<b>ORION EVO - 2 x 600 mm - 5 decks</b>												
602/5.120	2242	1812				4268			7.2	3.4	3107	Consult us
602/5.160	2656	2226				5052			9.6	4.2	3478	Consult us
602/5.180	2868	2438	1889	2682	2200	5634	2093	2301	10.8	4.6	4291	Consult us
602/5.200	3062	2632				5828			12	5.0	4482	Consult us
602/5.220	3272	2842				6427			13.2	5.4	4648	Consult us
602/5.240	3467	3037				6622			14.4	5.7	4829	Consult us

6 deck depth choices: 120, 160, 180, 200, 220 and 240cm

\* with INTUITIV'2 and power reduction enabled

# ORION EVO Technical Data

Technical features												
Models	Overall depth	Floor depth	Oven width	Overall height	Frontal oven height	Oven + loader depth	Oven depth with integrated lifter	Height with integrated lifter (excluding loader + stop)	Baking area	Floor area	Total weight of the empty assembled oven, no base, no option	Connection power
	A	B	C	D	E	F	G	H	(m <sup>2</sup> )		(kg)	
(mm)												
<b>ORION EVO - 2 x 800 mm - 3 decks</b>												
802/3.120	2252	2204				4242			5.7	5.2	1811	Standard electricity tariff*
802/3.160	2666	2618				5026			7.7	6.1	2125	Standard electricity tariff*
802/3.180	2878	2830	2345	2682	2200	5608	2549	2301	8.7	6.6	2314	Consult us
802/3.200	3072	3024				5802			9.7	7.1	2474	Consult us
802/3.220	3282	3234				6401			10.7	7.6	2612	Consult us
802/3.240	3477	3429				6596			11.6	8.0	2777	Consult us
<b>ORION EVO - 2 x 800 mm - 4 decks</b>												
802/4.120	2252	2204				4242			7.7	5.2	2143	Consult us
802/4.160	2666	2618				5026			10.3	6.1	2555	Consult us
802/4.180	2878	2830	2345	2682	2200	5608	2549	2301	11.7	6.6	2765	Consult us
802/4.200	3072	3024				5802			12.9	7.1	2965	Consult us
802/4.220	3282	3234				6401			14.3	7.6	3177	Consult us
802/4.240	3477	3429				6596			15.5	8.0	3360	Consult us
<b>ORION EVO - 2 x 800 mm - 5 decks</b>												
802/5.120	2242	1812				4242			9.6	4.2	2496	Consult us
802/5.160	2656	2226				5026			12.9	5.2	2984	Consult us
802/5.180	2868	2438	2345	2682	2200	5608	2549	2301	14.6	5.7	3216	Consult us
802/5.200	3062	2632				5802			16.2	6.2	3473	Consult us
802/5.220	3272	2842				6401			17.9	6.7	3723	Consult us
802/5.240	3467	3037				6596			19.4	7.1	3961	Consult us
<b>ORION EVO - 3 x 600 mm - 4 decks</b>												
603/4.180	2878	2830	5608	2665	2465	2682	2200	2301	13	7	4227	Consult us
603/4.200	3072	3024	5802	2665	2465	2682	2200	2301	14,4	7,5	4452	Consult us
603/4.220	3282	3234	6401	2665	2465	2682	2200	2301	15,8	8	4691	Consult us
603/4.240	3477	3429	6596	2665	2465	2682	2200	2301	17,3	8,5	4896	Consult us
<b>ORION EVO - 3 x 600 mm - 5 decks</b>												
603/5.180	2878	2438	5608	2665	2465	2682	2200	2301	16,2	7	5429	Consult us
603/5.200	3072	2632	5802	2665	2465	2682	2200	2301	18	7,5	5719	Consult us
603/5.220	3282	2842	6401	2665	2465	2682	2200	2301	19,8	8	6000	Consult us
603/5.240	3477	3037	6596	2665	2465	2682	2200	2301	21,6	8,5	6246	Consult us

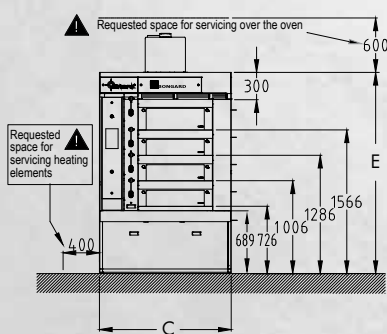

FRONT VIEW WITHOUT INTEGRATED LIFTER

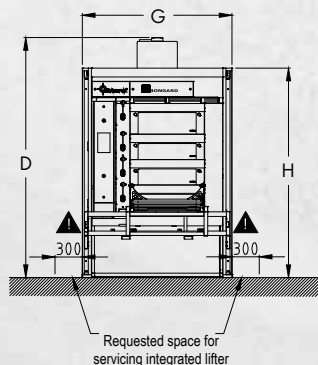

FRONT VIEW WITH INTEGRATED LIFTER

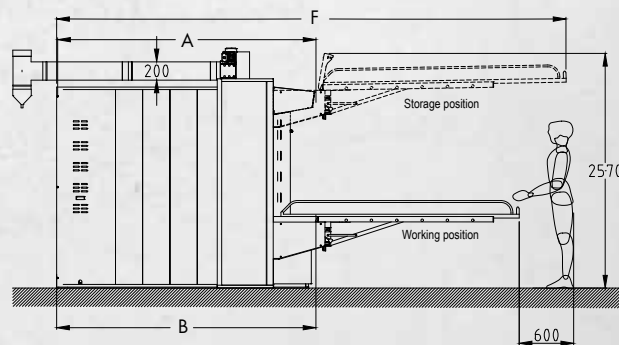

SIDE VIEW WITH INTEGRATED LIFTER



**BONGARD**, French manufacturer of bakery equipment since 1922, relies on a network of exclusive dealers continuously trained on all our ranges to ensure 7/365 commercial and technical service throughout France and the French overseas departments and territories. **BONGARD** is also distributed in more than 140 countries around the world.

To find a distributor near you, please go to:  
<https://www.bongard.fr/en/distributor/>



Follow us:     Bongard.bakery

**BONGARD**

32 rue de Wolfisheim - 67810 HOLTZHEIM (France) - Tel. +33 3 88 78 00 23 - [www.bongard.fr](http://www.bongard.fr) - [bongard@bongard.fr](mailto:bongard@bongard.fr)

an Ali Group Company



The Spirit of Excellence